

	Dual Support	Single Support (Cantilever)									
Distance From Attachment (CG) (IN)	0	6	12	18	24	30	36	42	48	54	60
R5000 Allowable Load (LBS)	5000	5000	2500	1650	1250	1000	825	700	625	550	500
R10000 Allowable Load (LBS)	10000	10000	5000	3333	2500	2000	1667	1429	1250	1111	1000

Assembly Powdercoated Black  
 Rotary Ground Included on tailstock  
 Hydraulic Clamping Optional

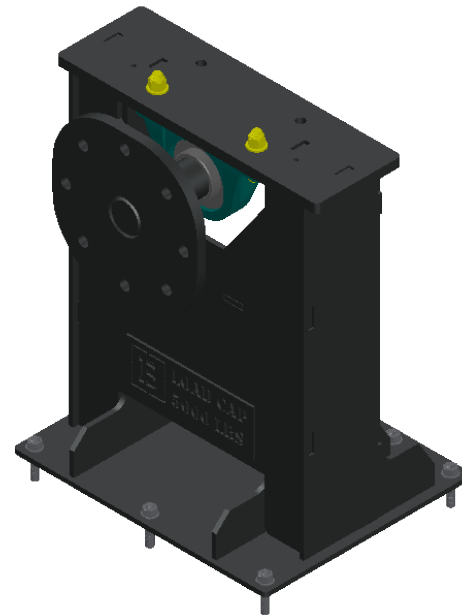
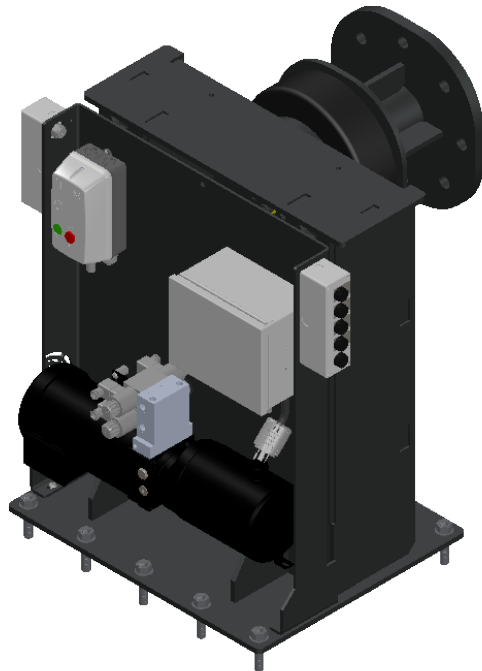

Weight(lb): 1515.0

THE INFORMATION CONTAINED IN THIS DRAWING IS THE SOLE PROPERTY OF BACKDRAFT MFG. ANY REPRODUCTION IN PART OR AS A WHOLE WITHOUT WRITTEN PERMISSION IS PROHIBITED.



NAME DATE  
 DRAWN TJL 11/19/2020

TITLE:  
 Dual Support Lift and Rotate  
 Assembly 5000lb

INTERPRET GEOMETRIC TOLERANCING PER: ASME Y14.5  
 UNLESS OTHERWISE SPECIFIED:  
 DIMENSIONS ARE IN INCHES  
 TOLERANCES:  
 FRACTIONAL ± 1/16  
 ANGULAR: MACH ±.5 BEND ±.5  
 TWO PLACE DECIMAL ±.035  
 THREE PLACE DECIMAL ±.005

SIZE A R5000 REV A

Saved: 12/2/2020 SCALE: 1:15 SHEET 1 OF 4

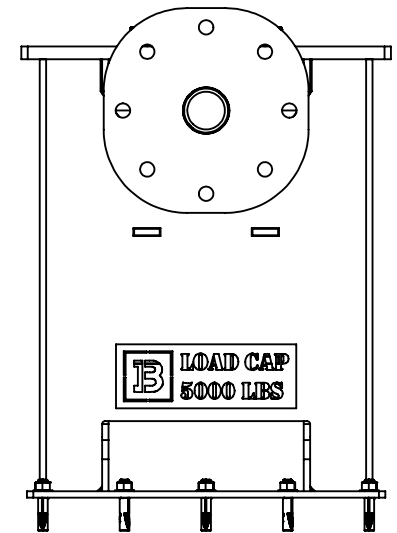
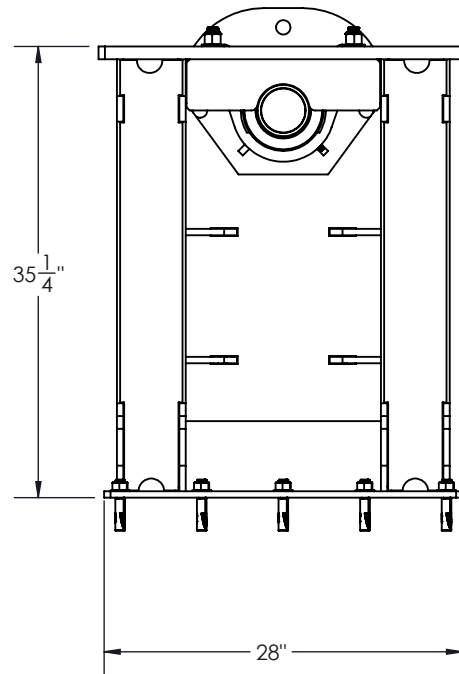
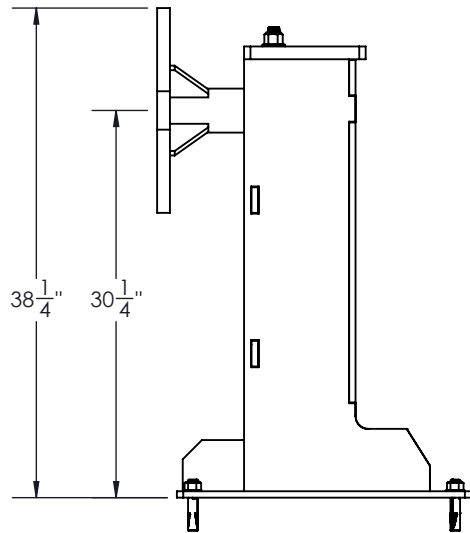
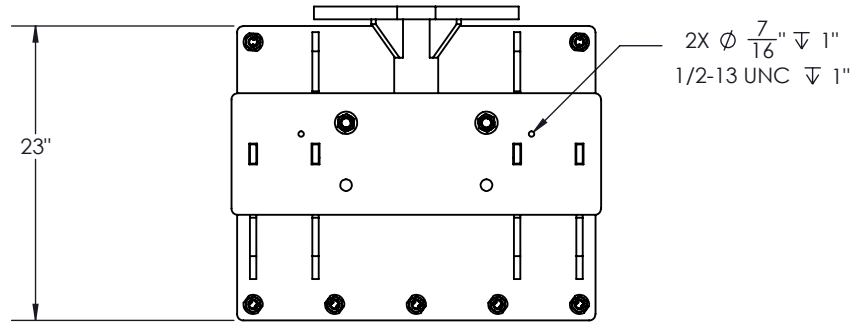

Weight(lb): 1515.0

THE INFORMATION CONTAINED IN THIS DRAWING IS THE SOLE PROPERTY OF BACKDRAFT MFG. ANY REPRODUCTION IN PART OR AS A WHOLE WITHOUT WRITTEN PERMISSION IS PROHIBITED.



NAME	DATE
DRAWN TJL	11/19/2020

TITLE:  
Dual Support Lift and Rotate  
Assembly 5000lb

INTERPRET GEOMETRIC TOLERANCING PER: ASME Y14.5  
UNLESS OTHERWISE SPECIFIED:  
DIMENSIONS ARE IN INCHES  
TOLERANCES:  
FRACTIONAL ± 1/16  
ANGULAR: MACH ± .5 BEND ± .5  
TWO PLACE DECIMAL ± .035  
THREE PLACE DECIMAL ± .005

SIZE <b>A</b>	R5000	REV <b>A</b>
------------------	-------	-----------------

Saved: 12/2/2020 SCALE: 1:15 SHEET 2 OF 4

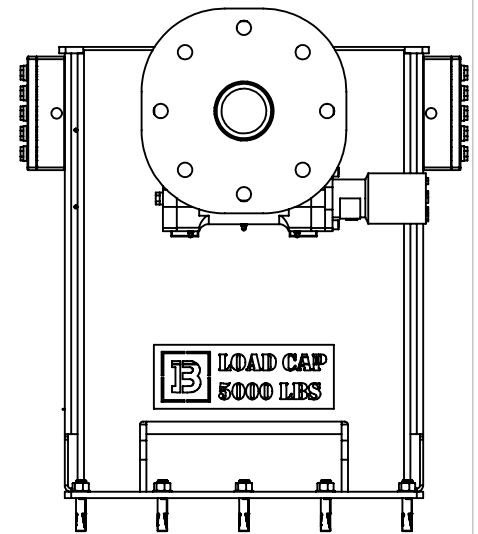
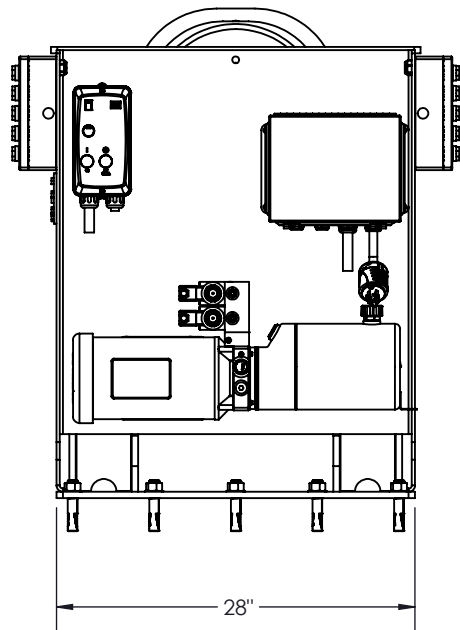
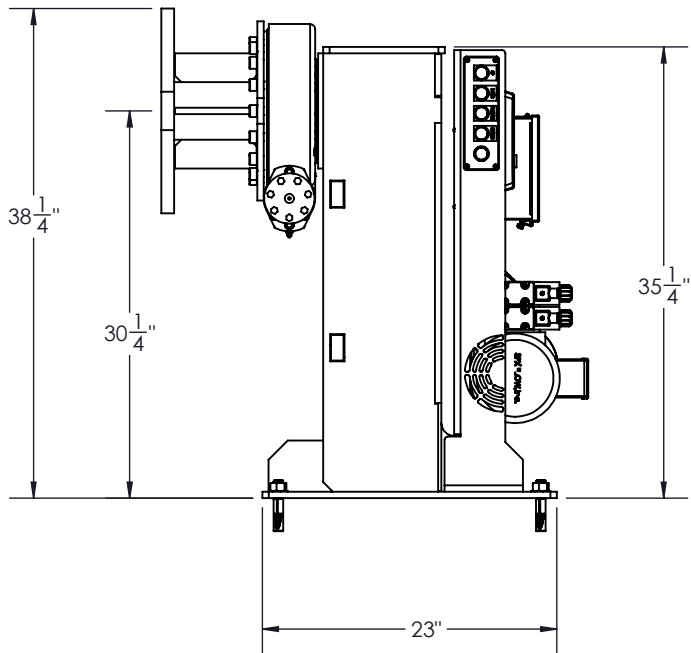
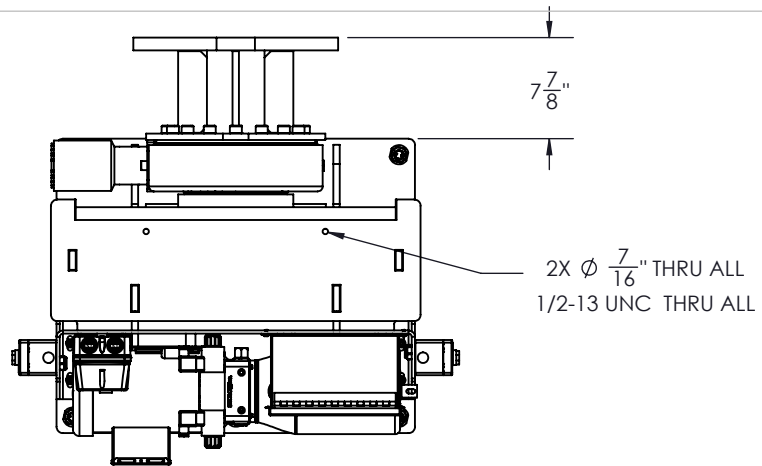

Weight(lb): 1515.0

THE INFORMATION CONTAINED IN THIS DRAWING IS THE SOLE PROPERTY OF BACKDRAFT MFG. ANY REPRODUCTION IN PART OR AS A WHOLE WITHOUT WRITTEN PERMISSION IS PROHIBITED.



NAME	DATE
DRAWN TJL	11/19/2020

TITLE:  
Dual Support Lift and Rotate  
Assembly 5000lb

INTERPRET GEOMETRIC TOLERANCING PER: ASME Y14.5  
UNLESS OTHERWISE SPECIFIED:  
DIMENSIONS ARE IN INCHES  
TOLERANCES:  
FRACTIONAL ± 1/16  
ANGULAR: MACH ± .5 BEND ± .5  
TWO PLACE DECIMAL ± .035  
THREE PLACE DECIMAL ± .005

SIZE <b>A</b>	R5000	REV <b>A</b>
------------------	-------	-----------------

Saved: 12/2/2020 SCALE: 1:15 SHEET 3 OF 4

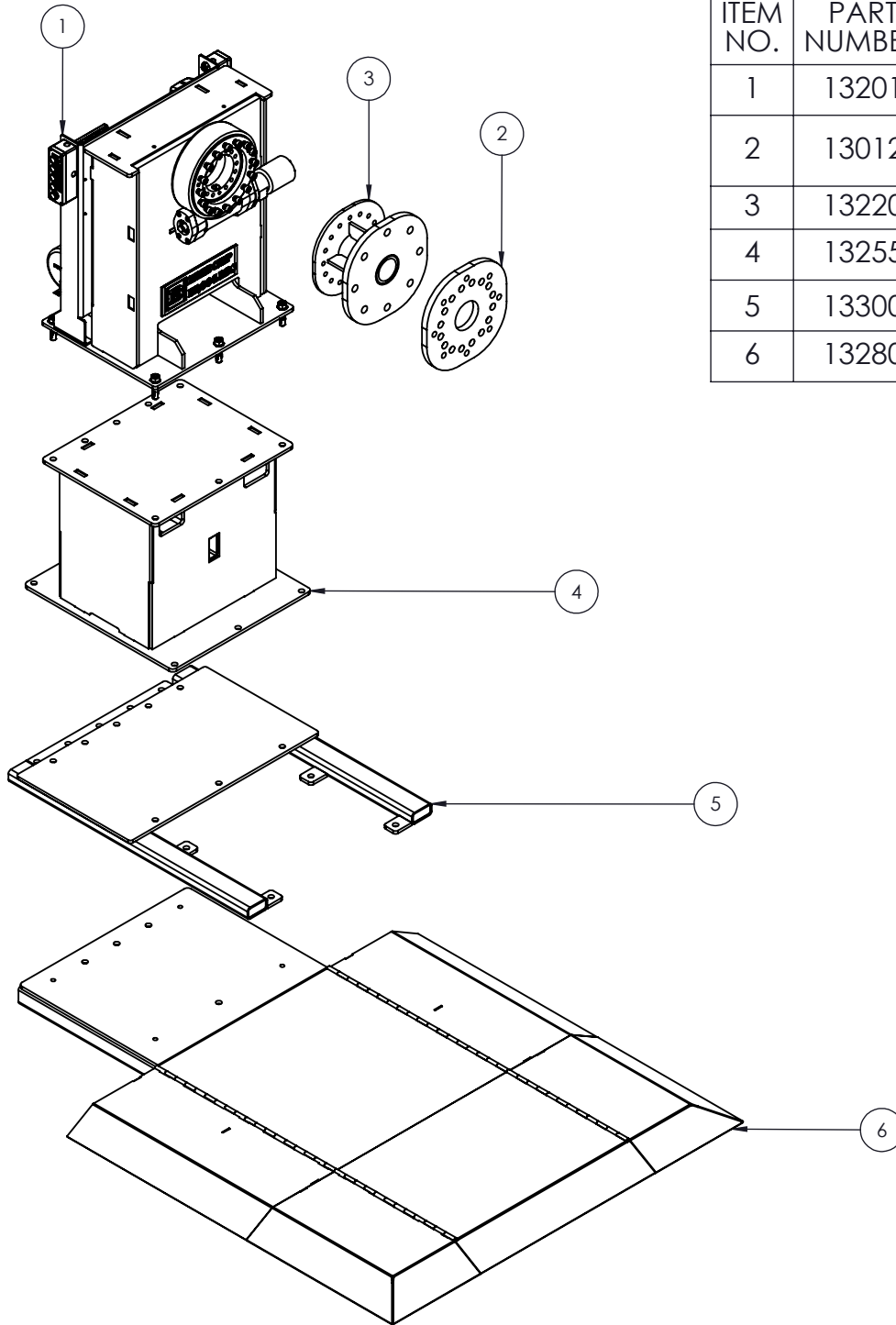

ITEM NO.	PART NUMBER	DESCRIPTION	Option
1	13201	Rotate Only Headstock	R5000-H__
2	13012	Sheet, Zero Clearance Headstock Adapter	R5000-H_0
3	13220	Rotate Only Headstock Adapter	R5000-H_1
4	13255	Headstock Pedestal Assembly (HSP)	R5000-HP__
5	13300	Headstock Cantilever Base	R5000-HC__
6	13280	Free Standing Pedestal Assembly	R5000-HF__

Weight(lb): 1515.0

<small>THE INFORMATION CONTAINED IN THIS DRAWING IS THE SOLE PROPERTY OF BACKDRAFT MFG. ANY REPRODUCTION IN PART OR AS A WHOLE WITHOUT WRITTEN PERMISSION IS PROHIBITED.</small>			
NAME	DATE	TITLE:	
DRAWN TJL	11/19/2020	R5000 Options	
<small>INTERPRET GEOMETRIC TOLERANCING PER: ASME Y14.5</small>		SIZE	REV
<small>UNLESS OTHERWISE SPECIFIED: DIMENSIONS ARE IN INCHES TOLERANCES: FRACTIONAL ± 1/16 ANGULAR: MACH ± .5 BEND ± .5 TWO PLACE DECIMAL ± .035 THREE PLACE DECIMAL ± .005</small>		A	R5000 A
Saved: 12/2/2020		SCALE: 1:25	SHEET 4 OF 4